

# Heavy Duty Single Deflection Grille

## Description

For supply or extract air, having single set of heavy duty, fully adjustable vanes to give directional control of the air pattern in two directions if required. Suitable for low, medium and high velocity installations.

## Construction

From extruded aluminium sections, frame 2.2mm thick, vanes 8mm thick max. Hairline mitres mechanically held. Optional OBD is of extruded aluminium.

## Size and Weight

From 100 x 100 to 1200 x 1200 in 25mm increments.  
Face mullions are incorporated when width exceeds 1200mm.  
Grille only 15kg/m<sup>2</sup>, Grille + OBD 24kg/m<sup>2</sup>  
Free Area approximately 80%

## How to Specify

STATE QUANTITY, THE PRODUCT CODING AND THE SIZE WIDTH X HEIGHT

e.g. 10 Qty. K110V+1D 300 x 150



Frame Style	Core	Options	Accessories
<b>K</b> 32mm Bevelled Flange	<b>11</b> Horizontal Vanes	<b>0</b> Fixed Core	<b>0</b> None
	<b>13</b> Vertical Vanes	<b>R</b> Removable Core	<b>V</b> Damper
	<b>10</b> Fixed Horizontal Vanes		

+

Fixings	Finish
<b>1</b> Flange Holes	<b>A</b> Satin Anodised
<b>2</b> Neck Fixings	<b>C</b> PPC BS / RAL Colour
	<b>D</b> Mill Finish

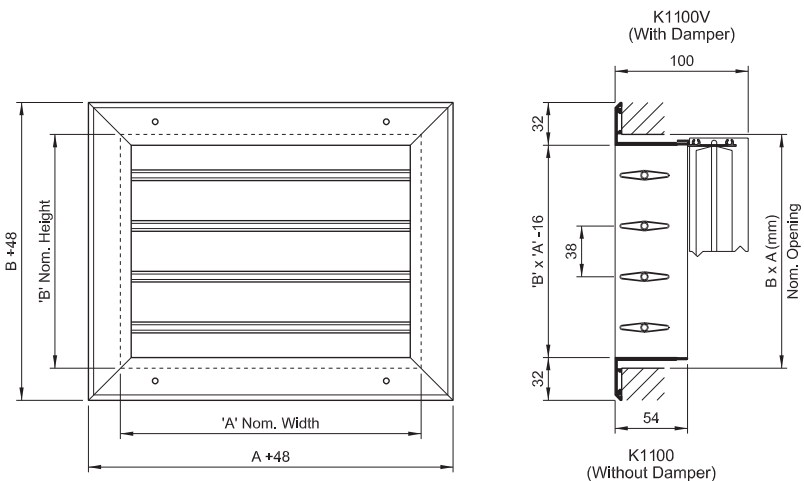

# Selection Data For Sidewall Mounted Grilles

## Basis of Technical Data

The following performance data is based upon sidewall products mounted 0.3M below a flush ceiling, a floor to ceiling height of 2.7M and supply air 10°C below room temperature. Satisfactory performance can be achieved with heating differentials to 14°C.

## Correction Factors

### Throw and terminal velocities

Lt in the performance tables represents the horizontal throw distance in metres from the supply air grille to that point at which the airflow envelope has a terminal velocity (Vt) of 0.25 m/s. The following table provides indication of the likely throw distance (Lt) at other terminal velocities.

### Terminal velocity

Vt (M/S)	0.25	0.37	0.5	0.62	0.75
Lt (Metres)	x 1.0	x 0.8	x 0.66	x 0.5	x 0.4

### Grille Positioning and multiple outlets

The following should be considered for applications requiring multiple outlet grilles:

To ensure good air distribution, multiple outlets must be correctly spaced:

<b>0°</b>	<b>Vane setting</b> -	Grilles should be mounted on equal centres to 33% of the throw distance (Lt).
<b>22°</b>	<b>Vane setting</b> -	Position grille centres at 50% of the throw distance.
<b>45°</b>	<b>Vane setting</b> -	Grille should be mounted on centres 'equal' to the throw distance (Lt).

The performance of multiple outlet grilles mounted in-line will greatly benefit by incorporating grille spigots and deflectair air turning vane devices.

### With ceiling assistance

Select a single grille to supply 155 l/s to give a throw 'Lt' of 5 metres with NC35 maximum and a room height of 2.7M.

- i) Enter the performance tables at volume q(l/s) 155 following the horizontal band and look to satisfy the two main criteria of 'Lt' and 'NC'.
- ii) You will find that a 4.8 metre throw 'Lt' intersects the 45° grille vane vertical column giving an NC rating of 30.
- iii) The 45° widespread air pattern is quite acceptable for single grille applications or when the centralines of multiple grilles equal the 'Lt' distance. NC30 is ideal as it allows scope for the possible regulation of the rear opposed blade volume control damper.
- iv) At the head of the vertical column a grille core area (Ac) of 0.051M<sup>2</sup> is given. A choice of four product sizes corresponding to this area are listed or the designer can choose a different size configuration of equal area. An a x b ratio of between 2:1 and 5:1 is preferable therefore size 400 x 150 is ideal.

### No ceiling application

If there is no ceiling the airflow envelope receives no 'coanda' assistance and will not therefore attain the same throw distance (Lt) as 'with ceiling assistance'. The same statement applies when supply grilles are mounted greater than 0.6M below a ceiling. In such instances the throw (Lt) will be reduced by 33%. To counteract this reduction the actual required throw must be increased x 1.5. The designer may then use the performance tables in the normal manner.

### NC (Noise Criteria)

Noise criteria values are shown in the performance tables for 0°, 22°, and 45° vane deflection angles (Da). Data is based on 8dB deduction for average room absorption and sound power level (Lw) 10<sup>-2</sup>W.

Grille 'NC' rating will be increased if two or more outlets are located within a floor plan area of 20M<sup>2</sup> or less. In such instances the following NC addition should be noted.

Supply Grille Qty. Within 20M <sup>2</sup>	2 Qty	3 Qty	4-6 Qty
NC Addition To Obtain Total Sound	+3	+5	+6

### Air volume adjustment

Rear opposed blade dampers are designed and intended for final 'trimming' of the air volume. Harsh adjustment will adversely affect pressure drop and noise, this should be avoided in critical applications. For guidance the closure of a damper by 25% will add 15Pa and 5Nc. Well positioned duct dampers for balancing a system and the inclusion of rear 'Deflectair' air turning devices should alleviate the need for harsh adjustment.

If no OBD multiply pressure drop x 0.89 and deduct 4Nc.

### Vertical downward projection of warm air into free space

Relatively high outlet jet velocities (Vj) are necessary to deliver warm air vertically downwards into free space (areas without vertical surfaces in close proximity to the air outlet source). Subsequently terminal velocity (Vt) and entrainment around the vortex will be greater than would normally be desired in the occupied zone. It is recognised however that the introduction of warm air by this method is sometimes unavoidable.

The following information provides a guide to performance:

- i) Recommended grille type S020V i.e. double set of adjustable vanes plus rear volume control damper.
- ii) Grille size range (a x b) 200 x 200 to 600 x 600 and maximum aspect ratio (a x b) 2:1.
- iii) Air volume range q(l/s) 100 minimum to 1000 maximum.
- iv) Maximum recommended mounting height from floor level 8M.
- v) Terminal velocity (Vt) at corrected throw distance (Lt) 0.40 M/s.
- iv) Apply the appropriate correction factor to the Lt values in the performance tables.

HEATING TEMP. DIFFERENTIAL (Td)	+2°C	+5°C	+10°C
THROW (Lt) CORRECTION FACTOR	x .90	x .65	x .45













# Technical Data Sidewall Mounted Supply Air Grilles

- S300V** 0° Fixed Blade
- S010V** Single Deflection
- S020V** Double Deflection
- K110V** Heavy Duty Single Deflection
- K120V** Heavy Duty Double Deflection

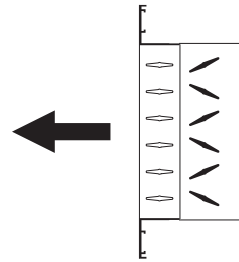

600 x 600 700 x 500 750 x 450 900 x 400 950 x 350 1200 x 300			750 x 600 900 x 500 1000 x 450 1150 x 400 950 x 350			750 x 750 950 x 600 1200 x 500 1300 x 450 1500 x 400			900 x 750 1050 x 600 1350 x 500 1500 x 450 1700 x 400			1000 x 750 1200 x 600 1500 x 500 1800 x 400			APERTURE A x B (mm)	
0.331M <sup>2</sup>			0.422M <sup>2</sup>			0.54M <sup>2</sup>			0.64M <sup>2</sup>			0.69M <sup>2</sup>			Ac(M <sup>2</sup> )	q(l/s)
0°	22°	45°	0°	22°	45°	0°	22°	45°	0°	22°	45°	0°	22°	45°	Da	
2.2	2.28	2.7	1.65	1.8	2.12	1.3	1.4	1.65							Vk(M/s)	550
10	8	5.7	7.8	6	4.3	5.6	4.3	3							Lt	
2	3	5	2	2	4	2	2	3							Ps	
18	19	24	-	15	20	-	-	-							NC	
2.25	2.46	2.91	1.77	1.93	2.28	1.39	1.51	1.79	1.17	1.28	1.5				Vk(M/s)	600
11	8.6	6	8.7	6.8	4.6	6.8	5	3.3	5.3	4	2.5				Lt	
3	4	5	3	3	4	3	3	4	2	2	3				Ps	
20	21	27	-	15	20	-	-	16	-	-	-				NC	
2.41	2.64	3.12	1.9	2.06	2.45	1.5	1.62	1.91	1.25	1.37	1.62				Vk(M/s)	650
12	9	6.7	9.5	7.3	5.3	7.3	5.3	3.8	6	4	2.5				Lt	
4	5	7	3	4	5	3	4	5	3	3	4				Ps	
22	23	28	16	17	23	-	-	17	-	-	-				NC	
2.66	2.9	3.42	2.08	2.28	2.69	1.65	1.78	2.1	1.38	1.5	1.99				Vk(M/s)	700
12.4	9.7	7	10.3	8	5.7	8.3	6	4.4	6.5	4.3	3				Lt	
4	5	9	3	5	6	3	4	5	3	3	5				Ps	
24	25	31	18	19	25	-	-	18	-	-	-				NC	
2.98	3.25	3.84	2.34	2.55	3.02	1.83	2	2.35	1.54	1.68	2				Vk(M/s)	800
13.5	11	7	11.3	9.2	6.2	9	6.8	5	7	5	3.5				Lt	
4	6	12	4	6	9	3	4	6	3	4	5				Ps	
27	28	34	21	22	28	15	17	22	-	-	16				NC	
3.23	3.51	4.15	2.52	2.75	3.26	2	2.15	2.55	1.67	1.82	2.15				Vk(M/s)	900
15	12	8	12.5	10	6.8	10	8	5.7	7.7	5.6	4				Lt	
5	7	13	5	7	12	4	5	10	3	4	8				Ps	
30	31	36	24	25	30	18	19	25	-	15	19				NC	
3.7	4.04	4.78	2.9	3.17	3.75	2.28	2.5	2.93	1.92	2.09	2.48	1.79	1.9	2.31	Vk(M/s)	1000
16	13	8.6	14	11	7.6	12	9	6.7	9	6.9	4.8	8	6	4.3	Lt	
6	7	20	5	8	16	5	6	12	4	5	10	2	4	8	Ps	
34	35	41	27	28	34	20	21	27	17	18	24	-	16	21	NC	
4.19	4.56	5.4	3.28	3.58	4.24	2.57	2.8	3.31	2.17	2.36	2.8	2.02	2.2	2.61	Vk(M/s)	1100
18	15	9.3	15.5	12.3	8.3	13	10.4	7	11	8.5	5.6	9	7.6	5	Lt	
11	15	25	7	12	20	6	8	15	5	8	15	4	6	10	Ps	
37	38	44	31	32	38	25	26	31	20	21	27	19	20	26	NC	
4.83	5.27	6.23	3.79	4.13	4.89	2.92	3.23	3.82	2.5	2.73	3.23	2.33	2.54	3	Vk(M/s)	1300
22	17	11	18	15	9.5	15	12	8.2	12.3	10	7.2	9.3	8	6.2	Lt	
15	25	38	10	15	28	7	10	19	6	9	16	4	8	13	Ps	
46	48	53	37	38	45	30	31	38	27	28	33	24	25	30	NC	
5.63	6.15	7.28	4.43	4.82	5.7	3.46	3.74	4.46	2.92	3.19	3.76	2.72	2.97	3.5	Vk(M/s)	1500
27	21	14	22	17	11	18	14	10.3	15	11	8.6	12	9	7.5	Lt	
16	30	43	13	18	32	9	15	28	8	13	24	5	10	18	Ps	
51	52	-	42	44	49	35	36	43	30	31	37	27	28	34	NC	
6.45	7	8.3	5.05	5.51	6.52	3.95	4.31	5.1	3.34	3.68	4.3	3.11	3.39	4	Vk(M/s)	1700
34	28	18	29	24	15	24	21	13	21	16	12	18	13	9	Lt	
19	33	50	15	25	38	11	18	32	10	14	28	7	12	25	Ps	
54	56	-	48	49	55	41	42	48	35	36	42	30	31	37	NC	
			6	6.54	7.74	4.7	5.12	6.05	4	4.32	5.11	3.7	4.03	4.77	Vk(M/s)	2000
			37	29	18	33	27	17	28	22	14	23	19	12	Lt	
			19	30	40	15	23	24	13	18	30	9	14	27	Ps	
			-	-	-	48	50	55	43	44	50	38	39	44	NC	
			7	7.5	9	5.5	6	7	4.6	5	6	4.3	4.7	5.5	Vk(M/s)	2400
			40	31	23	35	29	19	32	25	16	26	21	14	Lt	
			25	37	55	19	28	40	16	24	37	13	17	29	Ps	
			-	-	-	-	-	-	52	42	-	48	50	55	NC	
			8.2	9	10.6	6.4	7	8.3	5.4	5.9	7	5	5.5	6.5	Vk(M/s)	2800
			45	37	23	38	32	22	33	28	19	29	24	16	Lt	
			30	48	65	25	34	48	20	25	40	16	21	34	Ps	
			-	-	-	-	-	-	-	-	-	-	-	-	NC	